

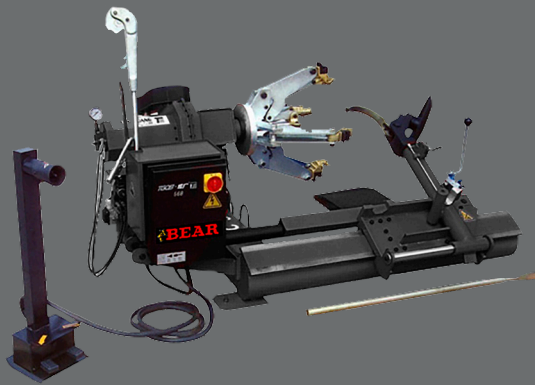

# *TIRE CHANGERS*

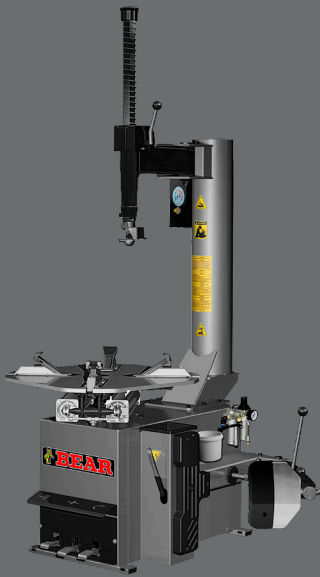

# SEMI-AUTOMATIC TIRE CHANGER

## 70-030

### SPECIFICATIONS

Max Rim Width	12" - 30"
Max. Wheel Diameter	47.5" (1200 mm)
Max. Wheel Width	15" (390mm)
Bead Breaker Force	3000 kg
Operating Pressure	140 psi (10 bar)
Power Supply	110v
Motor Power	0.55kw / 0.75kw
Max. Spindle Torque	1200 Nm
Max. Inflating Pressure	50 psi (3,5 bar)
<u>GROSS WEIGHT</u>	<u>530LBS (240KG)</u>

- Fixed vertical arm
- Horizontal moving arm
- Operating arm manual locking
- GT inflating device built inside the vertical arm
- 28" turntable
- Air operated bead breaker
- Extractable pedal unit
- Oversize body



Press arm. Pneumatic device to facilitate the operations for mounting/removing low profile tires, to be used with tire changer model 70-030B.

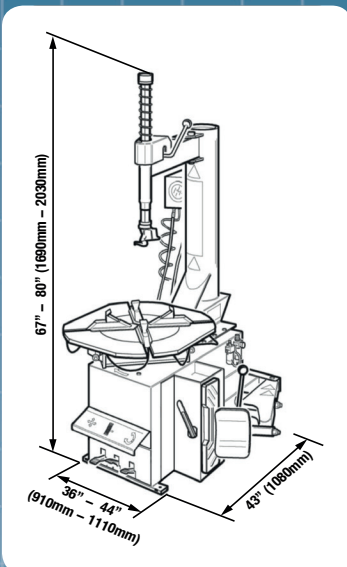

kit of 4 adapters for motorcycle wheels



Shown with optional assist arm

# AUTOMATIC TIRE CHANGER

## 70-035-B

### SPECIFICATIONS

Max Rim Width	12" - 30"
Max. Wheel Diameter	47.5" (1200 mm)
Max. Wheel Width	17" (450 mm)
Bead Breaker Force	3000 kg
Operating Pressure	140 psi (10 bar)
Power Supply	110v
Motor Power	0.8kw / 1.1kw
Max. Spindle Torque	1200 Nm
Max. Inflating Pressure	50 psi (3,5 bar)
Gross Weight	684lbs (310 kg)

- Tilting vertical arm with pedal control
- Pneumatic system for locking the operating arm
- 28" turntable
- Bead-Breaker with double effect
- pneumatic cylinder
- Oversize body
- Extractable pedal unit
- Double turntable speed for 3PH



Press arm. Pneumatic device to facilitate the operations for mounting/removing low profile tires, to be used with tire changer model 70-035B.

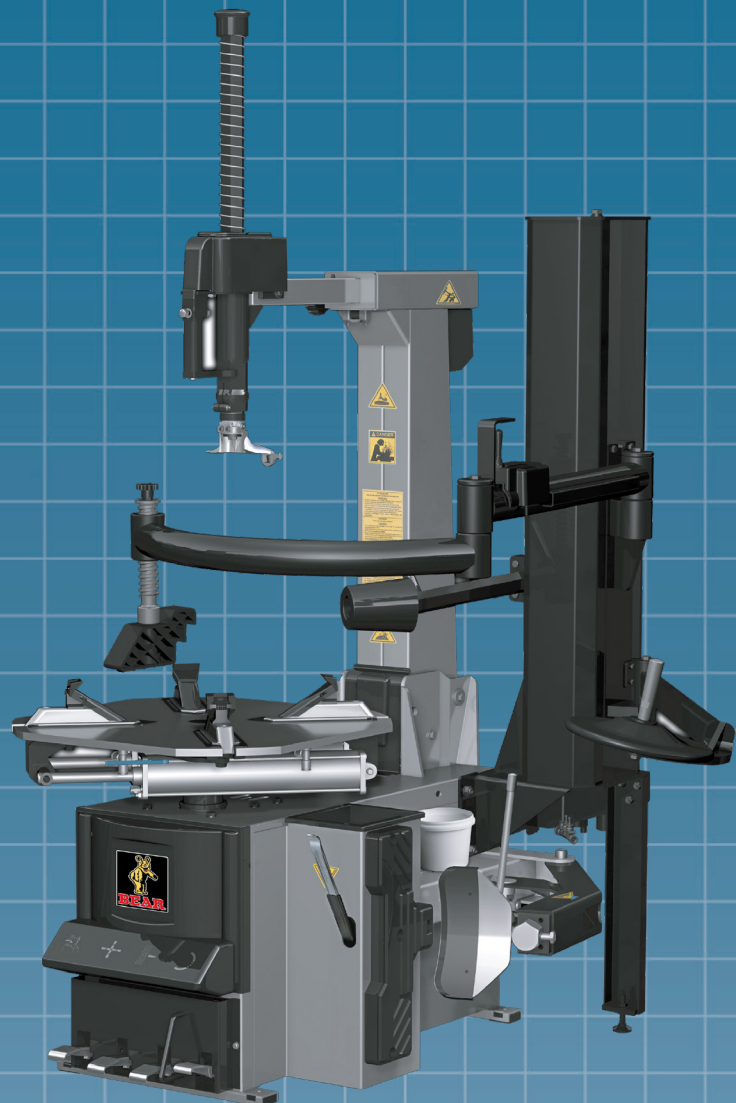
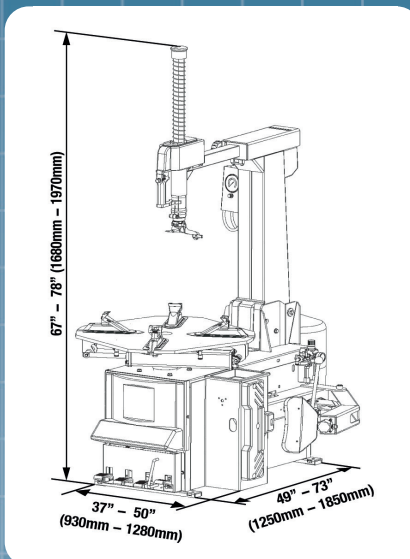

Shown with optional assist arm

# TRUCK TIRE CHANGER

## 70-109-6

This HEAVY-Duty model is designed to handle rim diameters from 14" - 26" . It can handle wheels with a maximum diameter of 63" and a maximum wheel width of 31" .

### SPECIFICATIONS

Max Rim Width	31"
Max. Wheel Diameter	63"
Internal Locking Diameter	14" - 26"
Operating Pressure	0 - 2300 PSI
Available Electrical Configuration	220v - 1ph or 220v 3ph
Net Weight	1150 lbs



**Distributed by:**

**BEAR – The Cartek Group**  
6950 East N Avenue  
Kalamazoo, Michigan 49048  
[www.bear-cartek.com](http://www.bear-cartek.com)  
Ph. 269-382-5080