



WHEEL BALANCER
Model: 80-406

CONTENTS

| | |
|---|-----------|
| 1 WHEEL BALANCER APPLICATION | 5 |
| 2 TECHNICAL DATA | 6 |
| 4 STRUCTURE AND PREPARATION FOR OPERATION | 8 |
| 4.1 General machine structure | 8 |
| 4.2 Preparation of the machine for operation | 9 |
| 4.3 Controls and indicators | 10 |
| 4.4 Switching the machine on. State “New Wheel” | 11 |
| 4.5 Using the menu | 11 |
| 5 WHEEL BALANCING | 12 |
| 5.1 Wheel balancing procedure | 12 |
| 5.2 Wheel mounting | 12 |
| 5.3 Wheel parameters input | 13 |
| 5.3.1 Weight setting scheme input (ALU schemes) | 13 |
| 5.3.2 Input of Dimensions | 14 |
| 5.3.3 Standard Input of Dimensions | 14 |
| 5.3.4 Input of Dimensions by direct measurement (recommended) | 15 |
| 5.4 Imbalance measurement | 16 |
| 5.5 Weight setting | 16 |
| 5.5.1 Weight setting in “12h” and “6h” positions | 16 |
| 5.5.2 Weight setting by the gauge arm..... | 17 |
| 6 EXAMPLES OF WHEEL BALANCING | 19 |
| 6.1 Standard wheel balancing | 19 |
| 6.2 Alloy wheel balancing (ALU) | 20 |
| 7 ADDITIONAL POSSIBILITIES | 22 |
| 7.1 The mode Split – “hidden weight” | 22 |
| 7.2 Effective work of three operators | 22 |
| 7.3 Adapter imbalance compensation | 22 |
| 7.4 Manual Input of Parameters | 23 |
| 7.5 Balanced Wheel Counter | 23 |
| 7.6 Recommendations on the wheel balancing | 23 |
| 8 WHEEL BALANCER SETTING | 24 |
| 8.1 Setting of wheel dimensions measurement mode | 24 |
| 8.2 Threshold of zero setting | 24 |
| 8.3 Start-up blocking | 24 |
| 8.4 Autoswitch to the «New wheel»: yes, no | 24 |
| 8.5 Shaft: Testing and calibration | 24 |
| 8.5.1 Shaft calibration testing | 24 |
| 8.5.2 Shaft calibration | 25 |
| 8.6 Electric gauge arms: testing and calibration | 25 |
| 8.6.1 Gauge arm diagnostics..... | 25 |
| 8.6.2 Gauge arm calibration | 25 |
| 8.7 Imbalance sensors: Testing and calibration | 26 |
| 8.7.1 Imbalance measurement accuracy check (simplified) | 26 |
| 8.7.2 Imbalance sensors calibration | 27 |

| | |
|---|------------------------------|
| 8.8 Software Version | 27 |
| 8.9 Service menu | 27 |
| 9 TROUBLESHOOTING | 28 |
| 9.1 Messages | 28 |
| 9.2 Other fault events and remedies | 29 |
| 10 MAINTENANCE AND SAFETY REQUIREMENTS | 30 |
| 10.1 Maintenance | 30 |
| 10.2 Safety requirements | 30 |
| 10.3 Instructions for emergency cases | 30 |
| 11 STORAGE AND TRANSPORTATION | 31 |
| 11.1 Storage | 31 |
| 11.2 Transportation | 31 |
| 11.3 Information on recycling | 31 |
| 12 MANUFACTURER'S WARRANTY | 32 |
| 13 CERTIFICATE OF ACCEPTANCE | 32 |
| APPENDIX A | 33 |
| APPENDIX B | 34 |
| Declaration of conformity | Error! Bookmark not defined. |

1 WHEEL BALANCER APPLICATION

1.1 The wheel balancer 80-406 (configurations: STANDARD and LUX (hereinafter referred to as “machine”) is designated for balancing car wheels with disc diameter up to 28 inches and width up to 20 inches.

1.2 Wheel balancing is carried out by taking one measurement for both correction planes with simultaneous indication of the mounting locations and mass of corrector weights.

1.3 The machine is equipped with an electronic gauge arm for automatically input of the diameter (up to 26 inches) and distance.

High accuracy of imbalance measurements allows balancing standard wheels by one cycle.

1.4 The wheel balancer 80-406, LUX configuration, is additionally equipped with a clamp for precise setting of stick-on weights and special functions of direct measurement of the parameters of the correction planes and precise setting of weights by the gauge arm. This improves the performance at balancing wheels when using stick-on weights.

1.5 The shaft of the machine is positioned so as to allow for maximum access to the inside of the wheel for easy setting of stick-on weights and cleaning space for them.

1.5 For sophisticated clients there is Split Function (behind-the-spoke-weight setting).

A thoroughly developed interface facilitates the machine mastering and makes further operation convenient and efficient. There is also a possibility of three operators' working on the machine.

1.6 Imbalance measurements can be fulfilled automatically when lowering the wheel cover. After measurements the wheel braking is fulfilled automatically.

1.7 To improve the accuracy of measurement the technology of reduction in engine vibration during measurement (NoiseDown) is used.

1.8 The machine is equipped with overvoltage protection device for supply mains (Power Guard technology).

1.9 For the machine functionality enhancement accessories and attachments of other producers, for example Haweka (Germany), Femas (Italy) may be mounted on the shaft. In particular, adapters for motorcycle wheels mounting, adapters for wheels without the central hole.

1.10 The shaft threaded part length (200 mm) allows using flanged adapters of these producers for better wheels alignment.

The shaft diameter is 40 mm, thread pitch is 3 mm.

2 TECHNICAL DATA

| | | |
|--|--|------------------------|
| 2.1 Machine type | stationary | |
| 2.2 Drive type | electromechanical | with belt transmission |
| 2.3 Wheel weight range, kg | 10...65 | |
| 2.4 Maximum wheel outer diameter, mm | 800 | |
| 2.5 Absolute error limit of imbalance measuring, gr*mm | ±800 | |
| 2.6 Imbalance measurements range, gr*mm | 0÷31000 | |
| 2.7 Power supply | (187...242) (50±1) Hz | VAC, |
| 2.9 Power consumption, W, max | 250 | |
| 2.10 Weight netto, kg, max | 80 | |
| 2.11 Overall dimensions (with raised cover), mm, max | | |
| - Length | 915 (800) ¹ 915 (835) ² | |
| - Width | 1150 (1150) | |
| - Height | 1170 (1250) | |
| 2.12 Operating temperature range, °C | +10 ÷ +35 | |
| 2.13 Shaft rotation speed, RPM | 150 ÷ 200 | |
| 2.14 Continuous operation durability | not limited | |

For configurations: ¹ – STANDARD
² - LUX

3 Accessories

Accessories of the machine are given in table 3.1

Table 3.1

| No | Denomination | Quantity, pieces. | Remarks |
|----|--|-------------------|---|
| 1 | Wheel balancer | 1 | |
| 2 | Operations manual | 1 | |
| 3 | Cover | 1 | |
| 4 | Shaft 40x3x180 with bolt | 1 | 40x3x240 on request |
| 5 | Adapter six-sided | 1 | Depending on execution of a threaded shaft bolt |
| 6 | Cone Ø78...114 | 1 | |
| 7 | Cone Ø62...82 | 1 | |
| 8 | Cone Ø43...70 | 1 | |
| 9 | Nut with plastic ring, cup and rubber ring | 1 | |
| 10 | Power wire | 1 | |
| 11 | Caliper | 1 | |
| 12 | Weight pliers | 1 | |
| 13 | Gauge calibre | 1 | |
| 14 | Plastic shaft | 4 | |
| 15 | Self-tapping screw 6x25 | 4 | |
| 16 | Bolt M12 with wacher M12 | 1 | |
| 17 | Packing | 1 | |
| 18 | JEEP set (cone Ø97...160 with ring) | 1 | On request |
| 19 | Silica gel | 1 kg | at transportation by sea |

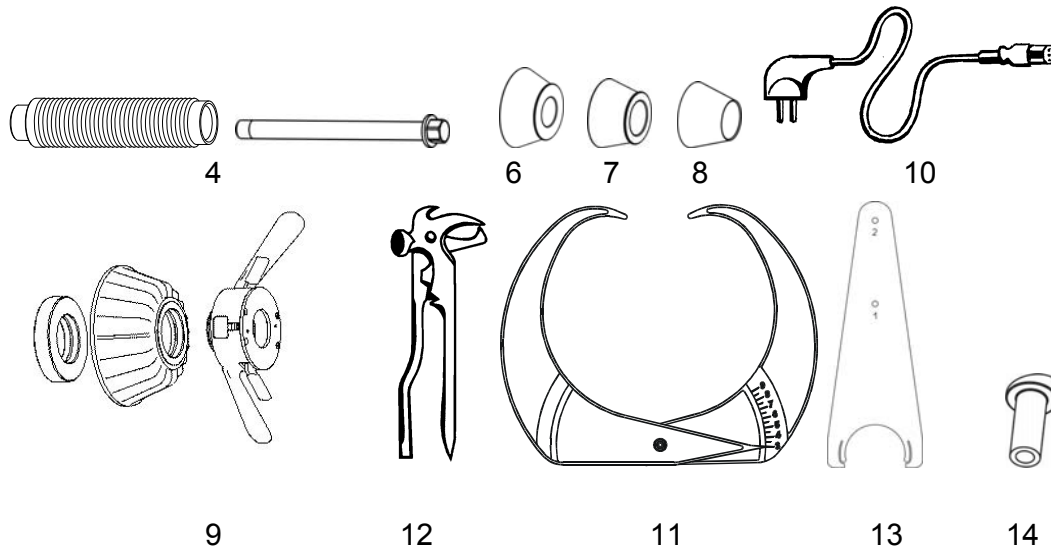

Figure 3.1 – Standard supplied accessories

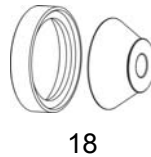

Figure 3.2 – Accessories supplied on request

4 STRUCTURE AND PREPARATION FOR OPERATION

4.1 General machine structure

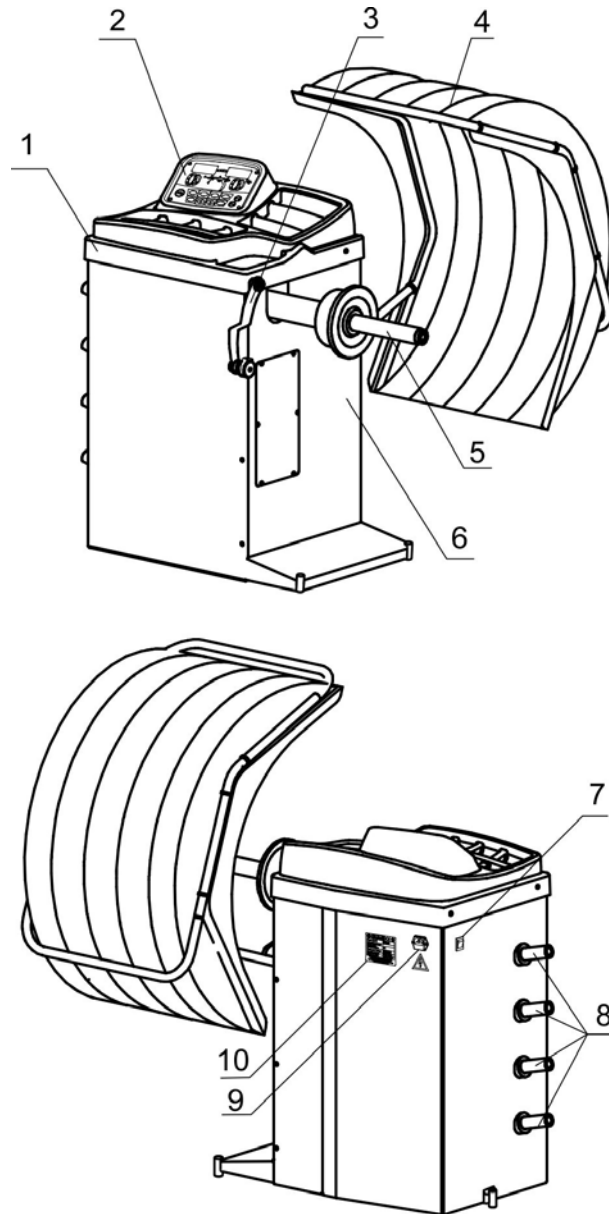

Figure 4.1

- 1 – plastic panel; 2 – control console; 3 – electronic gauge arm;
4 – protecting cover; 5 – shaft, $\varnothing 40 \times 3$; 6 – body; 7 – main switch;
8 – plastic shafts for cones and caliper; 9 – mains plug with fuse for main cable connection; 10 – nameplate.

The wheel to be balanced is fixed on drive shaft (5) by locking nut with centering cone or flange. The measurement of the diameter and distances to the wheel is made by the electronic gauge arm (3). For protection from splashes and safe operation there is protective cover (4) fixed on the machine body. There are cells for weights setting on the panel (1).

4.2 Preparation of the machine for operation

4.2.1 Unpack the machine. During the unpacking be careful not to damage the machine by unpacking tools.

After unpacking make visual check of the machine in order to find damages, which may occur during transportation, read carefully technical documentation enclosed, check the availability of accessories in accordance with the delivery set.

ⓘ After transportation or storage of the machine at an air temperature lower than +5°C it's necessary to keep the machine at a temperature of (25 ± 10) °C during minimum 4 hours before unpacking.

4.2.2 Place the machine on an even rigid foundation, admissible deviation of the foundation from the horizontal line is 0.5° (8 mm per 1m), so that all supports of the machine touch the foundation.

For safe and convenient operation of the machine it's recommended to locate it minimum 700 mm from the walls.

It's prohibited to locate the machine near sources of vibration, heat and electromagnetic fields, as it may reduce the accuracy of measurements of the machine.

4.2.3 Assemble shaft in accordance with Figure 4.3. Clean the machine spindle hole and shaft from preserving grease by rag moistened in petrol or white spirit. In accordance with Figure 4.3 set shaft 2 on machine spindle 1 fastening it by bolt 3 with torque 40 N·m, using adapter six-sided if necessary. During removal of the shaft it's allowed to tip slightly on the surface "B" (on horizontal surface) by a rubber or wooden hammer. Do not apply force along the spindle axis (for example, during transportation, during wheel mounting and dismounting)!

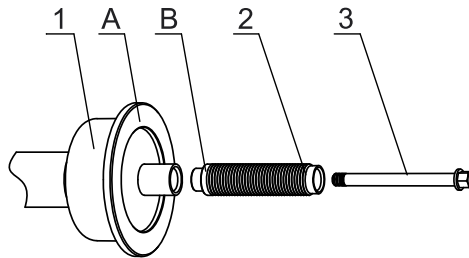

Figure 4.3 – Shaft assembling

4.2.4 Mount the cover as shown on Figure 4.4a. Before tightening the bolt by aligning the pins on the cover side with the grooves on the axis, Figure 4.4 b.

4.2.5 Mount plastic shafts (4 pcs) to the body using self-tapping screw 6x25.

4.2.6 Check the mains voltage conformity to the voltage indicated on the machine nameplate.

4.2.7 Connect the power supply cable to the machine jack, located on the rear panel of the machine body (figure 4.1), and to the supply mains equipped with the mains socket with the grounding contact.

4.2.8 Fulfill the shaft balancing and balance a standard wheel for testing after the machine installation.

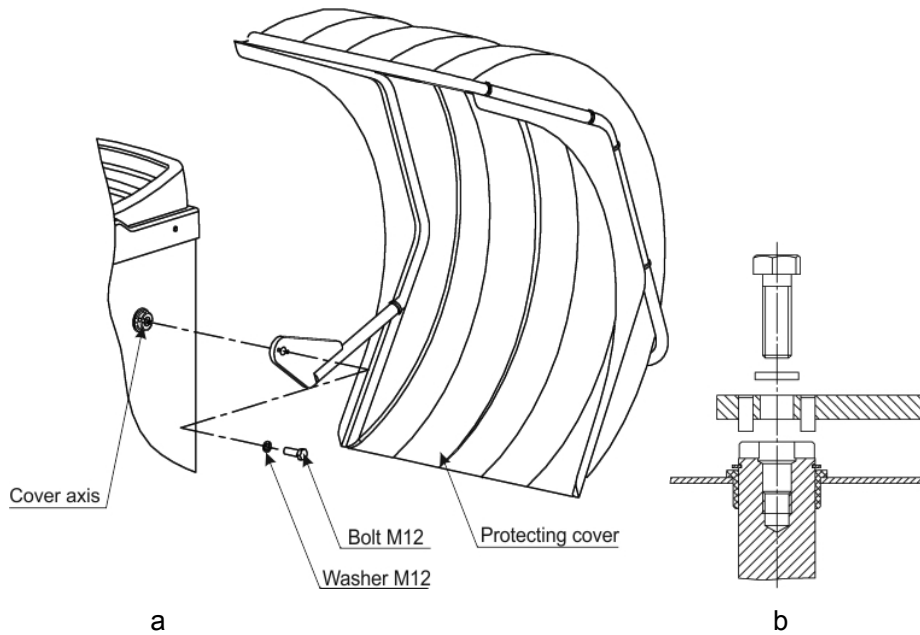
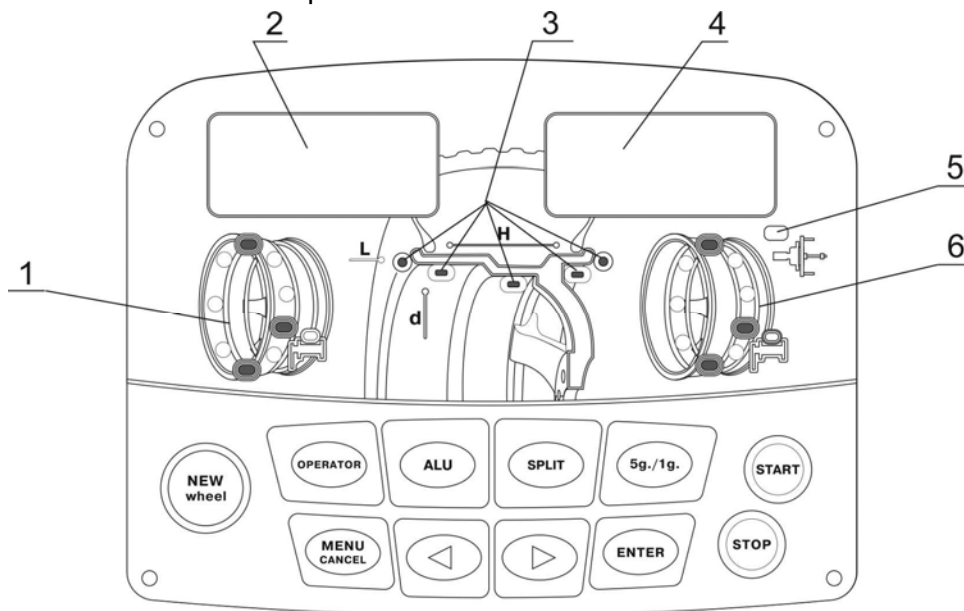

Figure 4.4 – Cover setting

4.3 Controls and indicators

Figure 4.5 shows the control panel.



1, 6 – weight position indicators; 2, 4 – digital indicators, 3 – weight location scheme indicator, 5 – adapter compensation mode indicator

Figure 4.5

The machine is controlled by using the keys:

NEW WHEEL –start of balancing a wheel; **OPERATOR** – operator selection,

ALU – weight setting scheme selection (ALU schemes);

SPLIT – behind-the-spoke-weight setting; **5 g/1 g** – rounding mode switch;

MENU/CANCEL –menu access or cancel of the current operation,

◀, ▶ - change of the current value or or search through the list of values;

- ENTER** – completion of data input;
- START** - starting rotation of the shaft and measurement of the imbalance;
- STOP** – emergency wheel stop during the imbalance measurement, temporary brake engagement when wheel dismounting and mounting.

4.4 Switching the machine on. State “New Wheel”

Before switch-on make sure that the gauge arm is in the initial position (Figure 4.6).

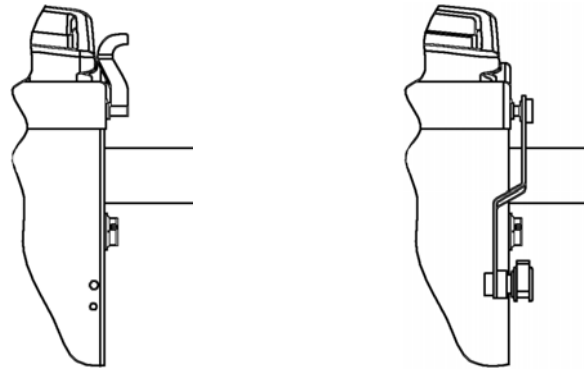

a – STANDARD configuration b – LUX configuration

Figure 4.6– Initial gauge arm position

Move the mains switch to the position ON.

After switch-on the machine will be in the mode “New Wheel”. In the mode the digital indicators show the operator number and operator selection is available, see the section 7.2.

The state “New wheel” is a base state of the machine. It is indicated by the sign **OPE** (operator) on the left indicator and the operator number on the right one.

The state “New wheel” allows for:

- ❑ Wheel parameters input (key **ALU**, gauge arm movement, keys **◀**, **▶**);
- ❑ Menu access (key **MENU**);
- ❑ Operator selection (key **OPERATOR**);
- ❑ Imbalance measurement (key **START**).

The transition of the machine to state “New wheel” may be effected by pressing the key **NEW WHEEL**, as well as automatically after the imbalance measurement with result **0 0**, as described in 8.4.

4.5 Using the menu

The menu is used for operating some machine functions.

The purpose and features of each program will be described in the following sections. The total list of programs is given in Appendix B. The following is a general procedure for working with the program menu.

To enter into the program menu is possible in the state “New Wheel”.

To enter the program menu press the key **MENU**. The left indicator will show the number of the program **PXX**, where **XX** is number of program, and the right indicator will show the program reference mark. Press the keys **◀**, **▶** to select the required program. To enter the selected program press the key **ENTER**. To quit the menu press **CANCEL**.

5 WHEEL BALANCING

5.1 Wheel balancing procedure

Balance the wheel in accordance with the following procedure.

- activate the machine state «New wheel» (4.4);
- prepare and mount the wheel (5.2);
- enter wheel data if necessary (5.3);
- fulfil the imbalance measurement (5.4);
- set weights if necessary (5.5);
- make check measurement (5.4).

5.2 Wheel mounting

ⓘ While wheel mounting it's necessary to remember that the machine should be kept clean. Avoid dust and moisture penetration inside the machine, water pouring and splashing on control panels and openings in the machine body.

Clean the wheel of mud and remove weights set earlier. Mount the wheel to be balanced on the machine drive shaft in accordance with Figure 5.1 depending on the wheel rim design.

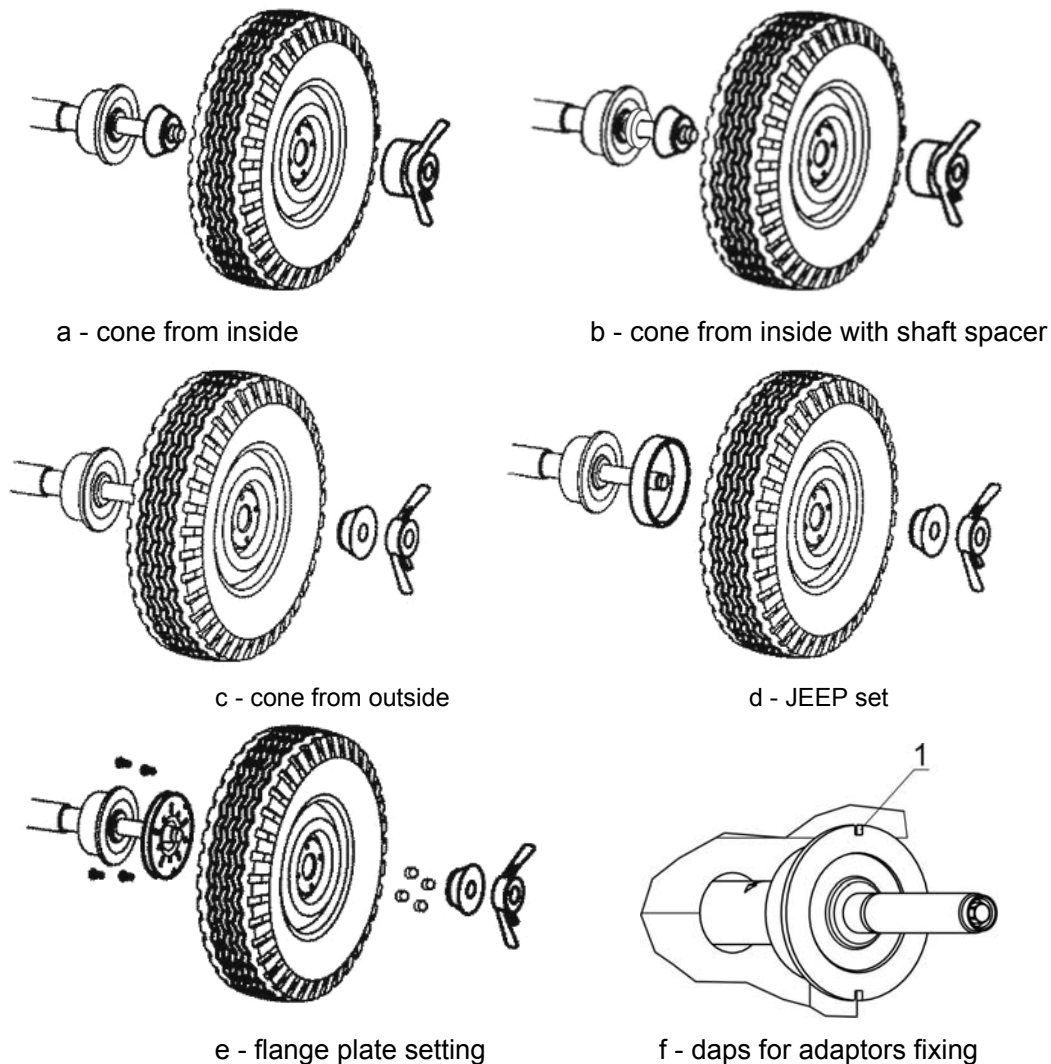

Figure 5.1 - Wheel mounting

It is recommended to mount the wheel with cone outside, Figure 5.1b in case of correct construction of the wheel and quality of the outer margin of the opening. In this case wheel centering is more correct and shaft and nut thread wear is much less.

Wheel mounting with shaft spacer delivered on request (Figure 5.1b) is recommended when the cone is mounted from inside, if the cone is set deeply in the wheel opening and insufficiently compresses the spindle spring while tightening up the wheel nut. The stronger the spring is compressed; the better is the wheel centering.

Wheel mounting on the flange plate adapter delivered on request (Figure 5.1e) imitates the wheel fastening on the car hub and allows balancing the wheel more precisely. Initially, it's necessary to fasten the flange on the wheel, and then mount the wheel with the flange on the machine spindle.

Parameters of the flange holes arrangement for wheel fastening bolts and the list of car models the wheels of which have the same fastening parameters is given in Appendix A.

For mounting motorcycle wheels and wheels without the central hole it's necessary to use special adaptors to be purchased separately. The adaptors should be mounted using daps or holes 1 in the shaft cup shown in Figure 5.1f.

After mounting the adaptors, fastened on the shaft in fixed position it's necessary to fulfil the procedure of their imbalance compensation according to clause 7.3. Deactivate the adaptor compensation mode after removing the adaptor.

① *The adaptor compensation procedure should be fulfilled before the wheel mounting!*

① *If the adapter's imbalance does not exceed 3 gr adaptor compensation is not necessary.*

While mounting the wheel it's initially recommended to draw it slightly by clamping nut leaving a small end float. Then turn the wheel for one revolution, rocking it by hands. After that completely tighten the nut. For better wheel centering it is recommended to raise it by left hand while tightening the nut.

① *In order to facilitate the wheel mounting and dismounting in mode «New wheel» it's possible to activate the shaft braking mode by pressing the button **STOP**.*

5.3 Wheel parameters input

① *If it is not necessary to change the parameters for example when the wheel is exactly the same as the previous one - you can immediately proceed to imbalance measuring.*

5.3.1 Weight setting scheme input (ALU schemes)

The machine allows for weight setting on the wheel on various schemes depending on the wheel design. The possible schemes are shown in Figure 5.2.

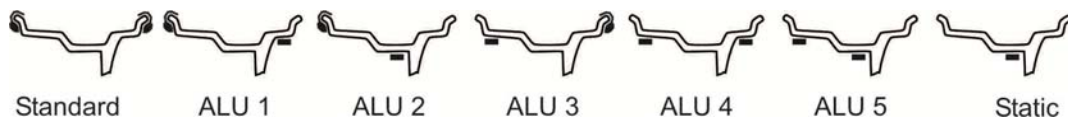

Figure 5.2 – possible weight setting schemes

The current scheme is always indicated on the control panel, figure 5.3.



Figure 5.3 – Weight location scheme indicator

To change a weight setting scheme press the key **ALU**. Then, by pressing the keys **◀** and **▶**, select the required scheme. Press the key **ENTER**. To cancel press the key **CANCEL**.

For the machine of LUX configuration the following actions depends on the selected scheme and direct measurement mode setting.

5.3.2 Input of Dimensions

Input of Dimensions is carried out in the state “New Wheel”.

Input of Dimensions is carried out by two possible ways: standard and direct measurement.

5.3.3 Standard Input of Dimensions

At standard input of dimensions of the wheel the following parameters shall be entered: disk diameter d , the distance from the machine to it L , and the width of the disk H , figure 5.4.



Рисунок 5.4 – Disc dimensions at standard input

Standard input of dimensions is carried out on:

- The machine of STANDARD configuration – for all weight setting schemes;
- The machine of LUX configuration when the direct measurement mode is disabled – for all schemes;
- The machine of LUX configuration when the direct measurement mode is engaged – for the schemes STANDARD, ALU1, ALU3 or ALU4 (figure 5.2).

For measurement of the distance and diameter move the gauge arm close to the wheel rim according to Figure 5.: for the machine of STANDARD configuration to the upper position, for the machine of LUX configuration to the lower position. The symbols **-d-** **-L-** will appear on the digital indicators for a short period of time, and then enter the value of the diameter (in inches) and distance (in mm). Wait for a sound signal. Move the gauge arm back into the initial position. To cancel the action press the key **CANCEL** before a sound signal

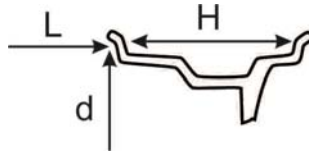
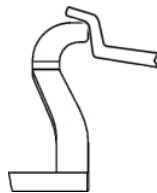

a - STANDARD

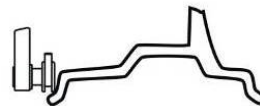

b - LUX

Figure 5.5 – Taking measurements by the gauge arm.

When the weight setting scheme Standard, ALU1, ALU3 or ALU4 is selected, i.e., scheme, when the right weight is set outside the wheel, you need to enter the wheel width.

Measure the wheel width by the caliper, Figure 5.6. By pressing the keys **◀**, **▶** enter the width. Enter the key **ENTER**. If the key **ENTER** is not pressed, the size will be fixed automatically in a several seconds. To cancel press the key **CANCEL** until a sound signal occurs.



Figure 5.6 – Measuring wheel width with a caliper

① When it is not possible to measure a wheel by the gauge arm, for example, when the wheel has a diameter of more than 26 inches, the parameters of the wheel shall be entered manually according ...

5.3.4 Input of Dimensions by direct measurement (recommended)

At direct measurement the operator using the electronic gauge arm directly measures the diameter and distance of the mounting points of the weights d_1 , L_1 , d_2 , L_2 , as shown in Figure 5.7. This increases the accuracy of the calculation of the masses and the positions of the balancing weights and reduces the number of cycles of balancing.

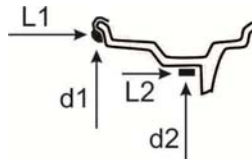

Figure 5.7 – Disc dimensions at direct measurement

Input of Dimensions by the direct measurement is possible only in the configuration LUX and for ALU2, ALU5 and Static, i.e weight setting schemes in which the right weight is located inside the wheel, Figure 5.8.

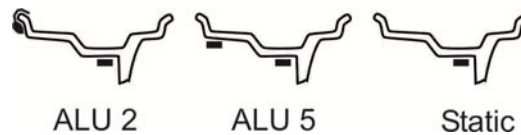

Figure 5.8 – Weight setting schemes, allowing for direct measurement

The direct measurement shall be enabled, as described in 8.1.

To fulfill the first measurement move the gauge arm to the setting location of the left weight as shown in Figure 5.9a or 5.9b, and hold it in this position. The indicators will briefly display symbols d_1 L_1 , and then - the value of the distance and diameter (in mm). Wait for a sound signal. To cancel the operation press the key **CANCEL** before the signal.

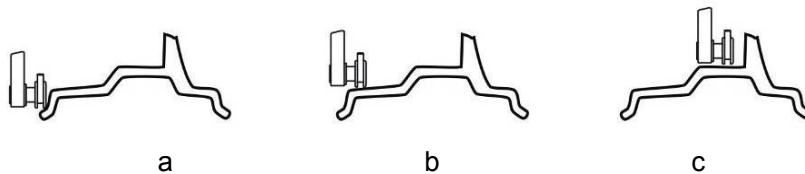

Figure 5.9 – Placing of the gauge arm at direct measurement

To fulfill the second measurement move the gauge arm to the setting location of the right weight as shown in Figure 5.9a or 5.9c, and hold it in this position. The indicators will briefly display symbols d_2 L_2 , and then - the value of the distance and diameter (in mm). Wait for a sound signal. To cancel the operation press the key **CANCEL** before the signal.

Move the gauge arm back to the initial position.

Pressing **CANCEL** will restore the dimensions that were before the measurement, and the transition into the mode "New Wheel".

5.4 Imbalance measurement

For the imbalance measurement lower the cover or press the key **START** with the lowered cover. Wait for the complete wheel stop. Raise the cover.

For emergency stop without completing the measurement press the key **STOP**.

Ⓣ During measurements mechanical effects on the machine are not allowed, it's not allowed to lean on the machine body, take from and put on the machine accessories, tools and other objects.

If the automatic transition into the state "New wheel" is allowed (8.4.) in case of «zero» results (0 0) the machine switches into the state "New wheel" in several seconds.

5.5 Weight setting

The machine will be switched over to the weight setting state after the imbalance measurement and wheel stop. For convenience, partial wheel braking will be activated automatically for some period of time.

The digital indicators show weight mass to be set.

Weight mass can be displayed roughly in accordance with the applied weight or precisely i.e. without rounding. When rounding is engaged weight mass is rounded up to 5 g. For clip-on weights over 60 g the mass is rounded up to 10 g. In addition, mass "zeroing" is performed.

To switch the rounding mode press the key **5 g/1 g**.

The indicators of the weight positions display the angular positions of mounting locations of weights. The glowing point shows, where the weight setting place is at the moment. When the wheel rotates the glowing point moves. Three points are highlighted on the indicator as shown in Figure 5.10:

- point 1 glows, when weight setting place is in the vertical upper position "12h";
- point 2 – in the vertical lower position "6h";
- point 3 – in the position for weight setting with the gauge arm.

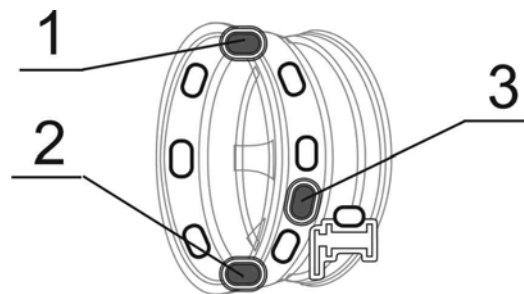

1 – weight in "12h", 2 – weight in "6h", 3 – weight setting with gauge arm

Figure 5.10 – Weight position indicator

The selection of the angular position of the weight during the setting depends on its type and is determined by ease of setting. For example, the clip-on weight can only be set to the "12 h" position. The stick-on weight can be set to the position "6 h" (recommended) or to the "12 h". For the machine configuration LUX the stick-on weight can be placed also with the gauge arm (recommended) according to 5.6.2.

5.5.1 Weight setting in "12h" and "6h" positions

To set the clip-on weight to position "12 hours", it is necessary to rotate the wheel by hand until you see the point 1, attach the load to the rim to the position «12 h", as shown in Figure 5.11a, and fix it on the rim by slight tapping with the tool.

When setting the stick-on weight it is important to observe not only the exact angular position of the weight, but also the distance - the distance to the edge of the wheel rim. Only under these conditions the wheel can be balanced for a minimum number of cycles.

To set the stick-on weight (with adhesive layer) remove the protective film from the weight. Then rotate the wheel by hand until the point 1 goes on - set the weight to the position "12 h", or 2 - for setting the weight to the position "6h", fix the weight on the wheel in the upper ("12 h") or lower ("6 h") position (Figure 5.11 b, c). If the dimensions of the wheel were entered by direct measurement, stick-on weights shall be set at the same distances, whereto the gauge arm was approached when entering dimensions. If the dimensions were entered in the standard mode, stick-on weights shall be set at a distance according Figure 5.12.

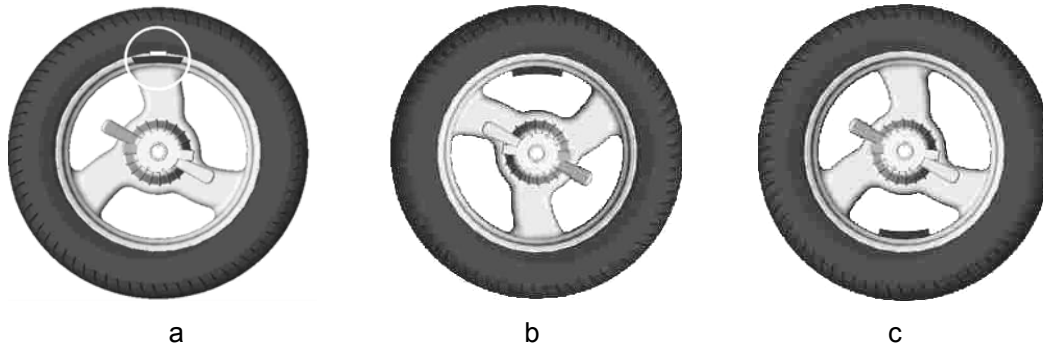

a – clip-on weight set in "12 h" position
 b - stick-on weight set in "12 h" position
 c – stick-on weight set in "6 h" position

Figure 5.11

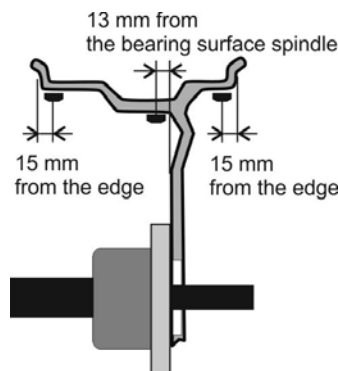

Figure 5.12 – Distances for stick-on weight setting

5.5.2 Weight setting by the gauge arm

When setting stick-on weights manually deviation unavoidably occurs that does not allow for balancing the wheel for one cycle.

Working on the machine of the configuration LUX there is a possibility to eliminate such deviation by weight setting by the gauge arm.

With the gauge arm you can set weights to the places accessible from the machine body, figure 5.10. If only one correction plane is accessible, the weight can be set in this plane by the gauge arm, and in the other plane in the mode "12-6h".



Рисунок 5.13 – Weight positions, accessible for setting be the gauge arm

Prepare the weight of the required mass. Remove the protective film from it.

Turn the wheel so that on the weight position indicator point goes on, as shown in Figure 5.14 a. Before the completion of the weight setting the wheel shall remain in this position.

Set the weight in the gauge arm clamp, as shown in Figure 5.14 b.

Having turned the gauge arm to the lower position, move forward the gauge arm until the intermittent sound signal and flashing of the load weight indicator occur. Press the gauge arm to the surface of the wheel, figure 5.14. By pressing the pusher, release the weight out of the gauge arm clamp. Move the gauge arm back to its initial position.

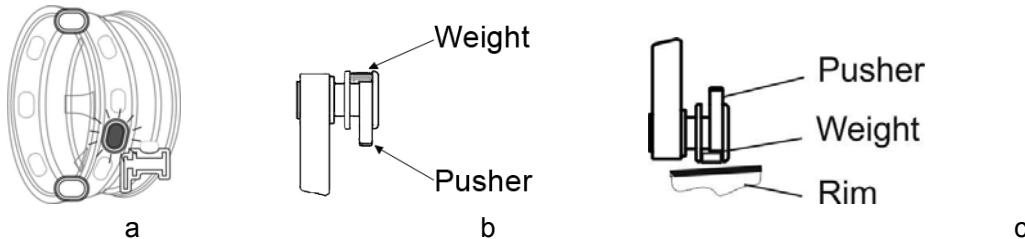

Figure 5.14 – Weight setting by the gauge arm

ⓘ When the gauge arm passes through the required distance, the machine produces a prolonged sound signal. Thus, when moving the gauge arm the sound signal occurs, you need to move the gauge arm in the opposite direction.

6 EXAMPLES OF WHEEL BALANCING

6.1 Standard wheel balancing

An example of the standard car wheel balancing with clip-on weights is given below.

If there is no sign **OPE** on the left indicator (the machine is not in the state "New wheel"), press **NEW WHEEL**.

Press **STOP** for temporary brake actuation.

Mount the clean wheel on the shaft (fig. 6.1).

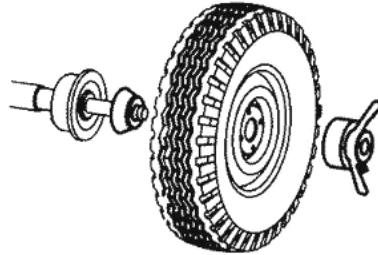

Figure 6.1 – Wheel mounting

Check the weight location scheme indicator. To change the scheme, press **ALU**. Then, by pressing **◀** and **▶**, set a scheme, figure 6.2 a. Press **ENTER**.

Enter dimensions. For this purpose place the gauge arm to the rim (Figure 6.2a) and hold it in this position until a signal is heard. Return the gauge arm to the initial position.

Measure the wheel width by the caliper, Figure 6.2 c. By pressing **◀** and **▶**, enter the width. Press **ENTER**.



a – weight setting scheme

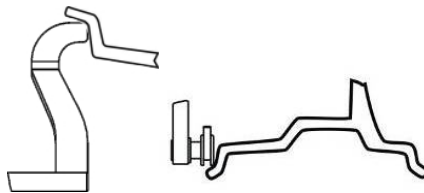

b – input of dimensions

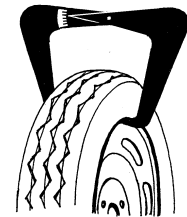

c – wheel width measurement

Figure 6.2 – Input of standard wheel parameters

Lower the cover for measurement. Wait for the wheel stop. Raise the cover. The information on weights will be imaged on the display. Prepare weights.

Turn the wheel manually until the point "12h" on the left weight position indicator goes on, Figure 6.3.

Set the weight of the given mass in "12 h" position on the left on the wheel rim, as shown in Figure 6.3.

Turn the wheel manually until the point "12h" on the right weight position indicator goes on. Set the weight of the given mass in "12 h" position on the right on the wheel rim.

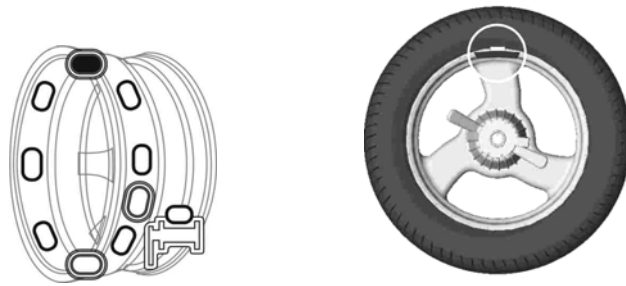

Figure 6.3 – Weight is set in the position “12h”

Lower the cover for the check measurement. Wait for the wheel stop. Raise the cover.

The information on weights will be imaged on the display. If the result is not equal to “0 – 0” set additional weights or change the position of the previously set weights and repeat the check measurement.

6.2 Alloy wheel balancing (ALU)

Let's consider the wheel balancing on the machine of the configuration LUX with the weights scheme shown in Figure 6.4., using direct measurement and weights setting by the gauge arm.



ALU 5

Figure 6.4

If there is no sign **OPE** on the left indicator (the machine is not in the state “New wheel”), press **NEW WHEEL**.

Press **STOP** for temporary brake actuation.

Mount the clean wheel on the shaft (fig. 6.5).

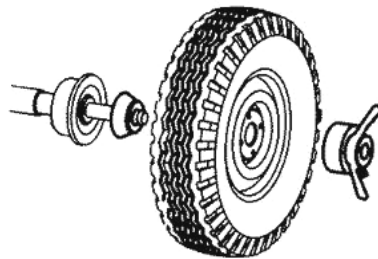

Figure 6.5 – Wheel mounting

Check the weight location scheme indicator. To change the scheme, press **ALU**. Then, by pressing **◀** and **▶**, set the required scheme. Press **ENTER**.

Enter dimensions. Firstly perform the first measurement. For this purpose place the gauge arm to the setting place of the left weight (Figure 6.6a) and hold it in this position until a signal is heard.

Perform the second measurement. For this purpose place the gauge arm to the setting place of the right weight (Figure 6.6b) and hold it in this position until a signal is heard.

Return the gauge arm to the initial position. .

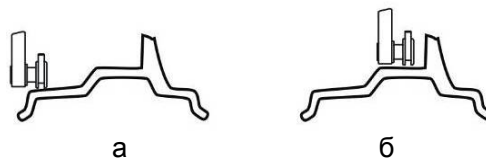

Figure 6.6 – Placing the gauge arm at direct measurement

Lower the cover for measurement. Wait for the wheel stop. Raise the cover.

The digital indicator will display weights masses to be set.

Set the left weight.

Prepare the weight displayed on the left. Remove the protection film from it.

Turn the wheel so that on the left weight position indicator the point goes on, as shown in Figure 6.7a. Before the completion of the weight setting the wheel shall remain in this position.

Set the weight in the gauge arm clamp, as shown in Figure 6.7b.

Having turned the gauge arm to the lower position, move forward the gauge arm until the intermittent sound signal and flashing of the load weight indicator occur. Press the gauge arm to the surface of the wheel, figure 6.7 c. By pressing the pusher, release the weight out of the gauge arm clamp. Move the gauge arm back to its initial position.

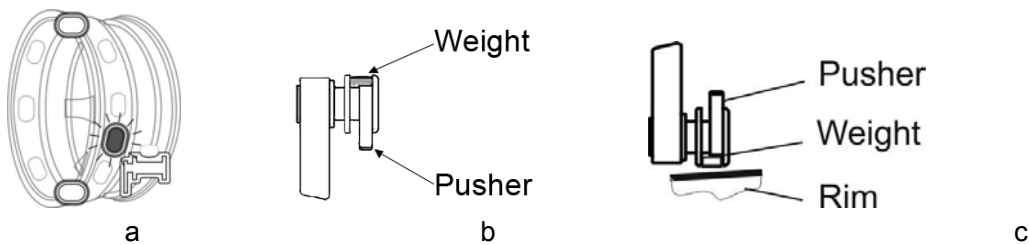

Figure 6.7 – Weight setting by the gauge arm

Set the right weight repeating all the operations but using the right indicators.

Lower the cover for the check measurement. Wait for the wheel stop. Raise the cover.

The information on weights will be imaged on the display. If the result is not equal to “0 – 0” set additional weights or change the position of the previously set weights and repeat the check measurement.

7 ADDITIONAL POSSIBILITIES

7.1 The mode Split – “hidden weight”

The Split mode allows maintaining the good appearance of the wheel at the expense of the stick-on weights setting behind spokes. This mode may be used for the right plane in schemes shown in Figure 7.1. That means that the weight hiding is performed only for one plane – the plane located behind spokes.

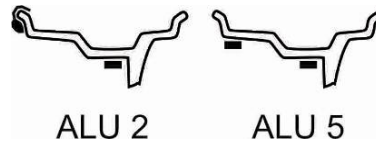

Figure 7.1 – Permissible weight setting schemes for the Split mode

In the majority of cases this is achieved by splitting one weight into two.

For entering the Split mode it's necessary to press **SPLIT** in the weight setting state. The right indicator will display the number of the spokes in the wheel. By the keys **◀**, **▶** enter the number of spokes in the wheel. By turning the wheel manually set any of the spokes to the position “12h”. Press **ENTER**.

If after this the position indicator will display two points of light at the moment or after rotation of the wheel, it means that two weights shall be set in the right plane. Their setting is similar to a normal setting of the stick-on weights.

By turning the wheel set weights in accordance with the information on the indicators.

① The Split operation will be fulfilled in accordance with entered quantity and position of spokes in all subsequent measurements till the transition to the state «New wheel».

To cancel the SPLIT mode, being in the weight setting state, press **SPLIT**, then - **CANCEL**.

7.2 Effective work of three operators

The machine ensures effective operation of three operators. For example, during the service of two-three cars the operators have to balance different wheels one by one. At the same time in order not to enter the wheel data once more it's sufficient for each operator to switch over the number (operator 1, 2 or 3) and the dimensions will be restored.

While “operator” changing over, for example, from 1 into 2:

- the current state of the machine and wheel parameters for “operator 1” are maintained;
- the machine state and wheel parameters for “operator 2” are restored.

The current number of “operator” is always displayed on the right indicator in the state “New Wheel”.

For “operator” change over press **OPERATOR** in the state “New Wheel”, until the desired number will be displayed on the right indicator.

7.3 Adapter imbalance compensation

Any adapter mounted on the shaft has its own imbalance, that introduces an error in the determination of own wheel imbalance.

For adapters mounted on the shaft by means of bolts through slots in the shaft cup, influence of this imbalance on the wheel balancing quality may be eliminated.

For this purpose it's necessary to perform the procedure of the adapter imbalance compensation.

Fasten the adaptor on the shaft.

Enter the menu by pressing **MENU**. The right indicator will display the program reference. By pressing **◀**, **▶** select the program **CPS** ("Adapter imbalance compensation"), enter it by pressing **BBO**. Then lower the cover for the imbalance measurement. After the shaft stops the indicator of the adapter compensation mode will glow (figure 4.4).

Mount wheels on the adapter and balance them according to the regular procedure.

Disable the adapter compensation mode after the adapter removal.

To disable the adapter compensation mode enter the menu, select the program **CPS** and press **ENTER**, and then press **CANCEL**. After this the indicator of the adapter compensation mode will be off.

① The adaptor compensation procedure should be fulfilled before the wheel mounting!

① If the adapter's imbalance does not exceed 3 g adapter compensation is not necessary.

7.4 Manual Input of Parameters

In some cases when for example it is impossible to use the gauge arm it is possible to enter diameter and distance manually.

Diameter should correspond to the wheel marking. Distance is an interval from the tip of the gauge arm in the initial position up to the rim in mm. It can be measured by a usual ruler.

To set the parameters manually enter the menu and select the program **P10 PAR** ("Manual input of parameters"). After setting the values for all parameters in such a way press **ENTER**. To cancel entered changes and exit manual mode press **CANCEL**.

7.5 Balanced Wheel Counter

The machine keeps records of balanced wheels that allow controlling fulfilled works. The counter value is increased by 1 when measuring the imbalance with the "zero result ". After the "999" counting begins with "0".

The counter is protected from any interference and it may only be looked through.

Trough the menu enter the option **P08 Cnt**. The right indicator will display the value of the counter. To exit press **ENTER** and **CANCEL**.

7.6 Recommendations on the wheel balancing



If during the control measurement after the weights setting it's required to set a small weight to the position shifted by 90 degrees from the set weight, it means that there is an error only in the angle position of the set weight. Shift the previously set weight by 5...10 mm.

If the error of the angle position appears constantly, it's necessary to re-calibrate the imbalance sensors more thoroughly observing the angle position "12 h" while setting the weight on the right, or set weights while balancing at once with a shift, also shifting the tape weight in the gauge arm clip.

8 WHEEL BALANCER SETTING

8.1 Setting of wheel dimensions measurement mode



Two modes are possible – standard and direct measurement. The features of each mode are described in 5.3. Setting is carried out through the program **P01 drt**, by activating and deactivating direct measurement.

Enter the program through the menu. The right indicator will display the state: **YES** – direct measurement is activated, **nO** - direct measurement is deactivated. Using ,  set the desired value. Press **ENTER**.

8.2 Threshold of zero setting

If the required weight mass is lower than the zeroing threshold, then the indicator will display "0". For example, if the threshold is fixed equal to 10 grams, then with the weights mass from 1 to 9 grams the indicator will display "0". The threshold is maintained even at disabled power supply. Zeroing is active only if the rounding mode is ON.

Zeroing threshold setting is performed in the program **P02 thr**.



Enter the program through the menu. The right indicator will display the value of the zeroing threshold. Using ,  set the desired value. Press **ENTER**.

8.3 Start-up blocking

Wheel imbalance measurement shall be performed only when the cover is lowered. Start-up blocking does not allow for electric motor start when the cover is raised.

Start-up blocking setting is carried out through the program **P07 Sft**.

If the value is «yes» then the imbalance measurement start-up is possible only with the lowered cover.

Enter the program through the menu. The right indicator will display the current setting: **YES** – blocking is on, **nO** – blocking is off. Using ,  set the desired value. Press **ENTER**.



 **WARNING!** It's not allowed to operate the machine if the blocking is off.

 Disabling of the blocking is allowed only for the duration of maintenance, observing all necessary safety rules!

8.4 Autoswitch to the «New wheel»: yes, no

Allows automatic transition into the «New wheel» state after reaching "0" imbalance on both planes.

The autoswitch setting is carried out through the program **P11 Aut**.

Enter the program through the menu. The right indicator will display the current setting: **YES** – yes, autoswitch is on, **nO** – no, autoswitch is off. Using ,  set the desired value. Press **ENTER**.

8.5 Shaft: Testing and calibration

Despite high accuracy of the machine its components have a small own imbalance. Shaft calibration excludes any influence of own imbalance upon measurements.

8.5.1 Shaft calibration testing

Testing should be performed at least 1 time per month.

While testing use precise (unrounded) imbalance values, displayed above the the weight setting scheme or disable the rounding in advance (8.1.1).

Remove all accessories from the shaft. Fulfil 3...5 imbalance measurements without the registration of results. Fulfil three imbalance measurements with the registration of results. The average imbalance values shouldn't exceed 1 g on each side. Otherwise, it's necessary to fulfill the shaft calibration.

8.5.2 Shaft calibration

Shaft calibration should be performed according to the results of the shaft testing (see 8.5.1) through the program **P05 CA.0**.

Remove all accessories from the shaft. Fulfill several measurements of imbalance.

*Through the menu choose the program. Lower the cover. Wait for the measurements completion. In case of danger for an emergency stop press **STOP**. After that, fulfill the shaft calibration testing according to 8.5.1.*

8.6 Electric gauge arms: testing and calibration

The imbalance calculation accuracy substantially depends on the wheel geometric parameters measurement accuracy. Inaccurate readings of the gauge arm may lead to the increase of measurement cycles (spin-ups) number during one wheel balancing.

8.6.1 Gauge arm diagnostics

Gauge arm diagnostics should be done during machine operation. The diameter shown during wheels measuring must correspond to tyre marking.

To check the distance measurement, measure the movement of the shaft of the electronic gauge arm from lock to lock by metric ruler. Then compare this value with the value of the distance displayed on the display. The difference should not exceed 2 mm.

In case of noncompliance of the diameter or distance gauge arm calibration should be performed.

Also, if standard wheel balancing by clip-on weights is fulfilled for more than one cycle, then the gauge arm probably measures inaccurately.

8.6.2 Gauge arm calibration

Gauge arm calibration is performed according to the results of the gauge arm diagnostics (see 8.5.1) in the program **P04 CA.L**.

Enter the program through the menu.

*The right indicator will display 1. Make sure that the gauge arm is in the initial position, press **ENTER**.*

*The right indicator will display 2. Push the gauge arm as far as it can go. Hold it in this state, press **ENTER**.*

The right indicator will display 3.

Set the gauge arm caliber on the shaft of the machine up to the stop, by orienting the caliber in the down position for the machine of the configuration LUX or in the up position for the configuration STANDARD, as shown in Figure 8.1.

*Put the tip of the gauge arm in the hole 1 of the caliber, as shown in Figure 8.1 a, c. Hold the gauge arm in this state, press **ENTER**.*

The left indicator will display 4.

Put the tip of the gauge arm in the hole 2 of the caliber, as shown in Figure 8.1b, d. the gauge arm in this state, press **ENTER**.

Gauge arm calibration is completed.

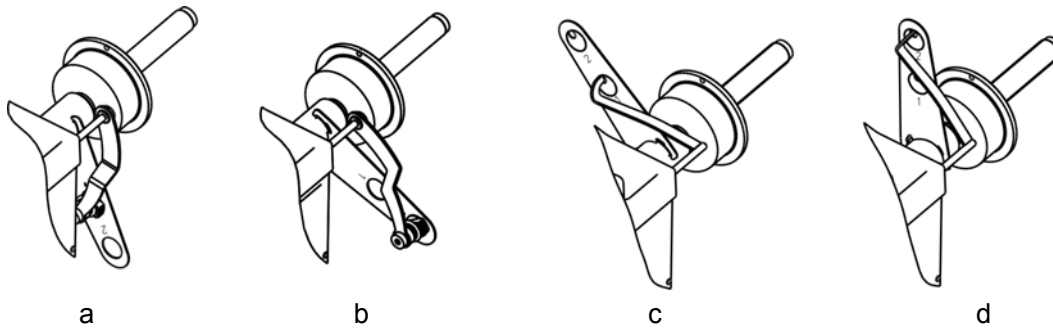

a, b – use of caliber in the configuration LUX
c, d – use of caliber in the configuration STANDARD

Figure 8.1

If the caliber is lost you can use a usual ruler. Set a butt of the ruler against shaft body. Move the edge of the gauge arm tip, touching the surface of the wheel rim, when measuring a wheel, up to the mark 133 mm instead of the point 1. Instead of the point 2 - up to the mark 223 mm.

8.7 Imbalance sensors: Testing and calibration

The imbalance sensors calibration is fulfilled in case of incorrect measuring of weight masses while standard wheels balancing, if standard wheel balancing can't be fulfilled during one cycle.

Imbalance sensors' testing is fulfilled by measuring accuracy of imbalance measuring.

8.7.1 Imbalance measurement accuracy check (simplified)

For imbalance measurement accuracy check it's necessary to take the wheel 13"…16" in diameter with the conditioned (without damages etc.) disc (radial and face runout of the weights setting point - maximum 1,5 mm) and clip-on weight with the mass (60…100) of ± 0.5 g. It should be possible to fasten clip-on weights on the edge of the wheel. The control weight should be weighted preliminary within the accuracy of 1 g.

The testing is fulfilled when the rounding is disabled.

Mount the wheel on the machine. Enter the wheel dimensions. Balance the wheel.

Fulfill adapter compensation procedure according to 7.5 without removing the wheel.

*Fulfill the regular measuring by pressing **START** - the result should no exceed 1 g. on each side. In other case it is necessary to repeat adapter compensation procedure.*

Fix the control weight in the right plane of the rim. Fulfill imbalance measuring, fix the result.

Move the weight to the left side, fulfill imbalance measuring, and fix the result.

Turn off adapter compensation according to 7.3.

Deviation from measured weight mass should not exceed 2 g+2% of control weight mass.

In other case:

- fulfill gauge arm calibration (8.5.2);
- fulfill imbalance sensors calibration;
- repeat the check.

8.7.2 Imbalance sensors calibration

Imbalance sensors calibration should be performed according to the results of imbalance measurement accuracy determination. It is recommended to fulfill gauge arm calibration first.

The calibration is fulfilled by 3 measurements: without weight, with weight on the right side, with weight on the left side.

For the calibration it's necessary to take the wheel 13"...16" in diameter with the conditioned (without damages etc.) disc (radial and face runout of the weights setting point - maximum 1,5 mm) and clip-on weight (60...100) of ± 0.5 g. It should be possible to fasten clip-on weights on the edge of the wheel.

Imbalance sensors calibration is performed through the program **P06 CA.S**.

Mount the wheel on the machine. Enter the wheel dimensions. Balance the wheel so far as the machine accuracy allows doing it.

*Enter the program **P06 CA.S**.*

*The indicators will display **0 0**. Do not set the weight. To start measurement, lower the cover. Wait for the wheel stop.*

*The indicators will display **0 <calibration weight>**. If actual calibration weight is differenced from indicated weight, set the actual value. Press **ENTER**, then by pressing **←** and **→** set the actual value of the calibration weight mass. Press **ENTER**.*

Turn the wheel till the point 1 ("12h") on the right weight position indicator goes on, Figure 5.10. Set the calibration weight on the right is strictly in the position "12h". To start measurement, lower the cover. Wait for the wheel stop.

*The indicators will display **<calibration weight> 0**. Turn the wheel till the point 1 ("12h") on the left weight position indicator goes on, Figure 5.10. Remove the weight from the right and set it on the left in the position "12h". To start measurement, lower the cover. Wait for the wheel stop. Remove the calibration weight.*

The calibration is completed.

To abort the calibration before it is completed - press **CANCEL**. In this case, the results of the previous calibration will remain in force.

Determine the imbalance measurement accuracy according to 8.7.1.

ⓘ During the calibration the angle position "12 h" should be especially observed while positioning the weight on the right. This angle error will lead to a constant angle displacement during measurements!

8.8 Software Version

Software Version Number is required for maintenance service of the machine.

To view the version, use the program **UEr**.

*Enter the program through the menu. The right indicator will display the version number. To exit press **ENTER** or **CANCEL**.*

8.9 Service menu

Service menu is for viewing the status of sensors and other machine operations when servicing the machine.

Service Menu access is carried out through the program **SEr SEr**.

*Enter the program through the menu. The right indicator will display the version. Press **ENTER**.*

Option selection is carried out as in the main menu. The Service Options are listed in the Appendix B, table B2.

If the selected service option, several parameters can be viewed, to select parameters use ◀, ▶. In this case, the right indicator will be display for a short period of time the parameter identifier, and then its value.

9 TROUBLESHOOTING

9.1 Messages

The built-in self-test system allows for a quick and accurate detection of a fault or malfunction.

The part of diagnostics is performed during the machine start-up, partly - during operation. Upon detection of an error, the indicator displays a message about this in the form of **Err FXX**, where **FXX** is the error code.

In addition, all the messages that have occurred for a session are stored in the message list.

These messages can be viewed through the option Er.L.

Enter the option through the menu. The right indicator will display the code of the recorded error. To view all the recorded errors, press ◀, ▶. In case of the machine malfunction eliminate causes acting in accordance with table 9.1.

Table 9.1

| Code | Description | Remedy |
|------|--|--|
| F02 | Shaft is not calibrated | Calibrate the shaft |
| F03 | Imbalance sensors are not calibrated | Calibrate imbalance sensors |
| F04 | Gauge is not calibrated | Calibrate gauge arm |
| F05 | Motor is on, but shaft don't rotate | To eliminate an external hindrance of rotation of a shaft Contact after-sales service office. |
| F07 | Noise on lines of the gauge of position of a shaft | Only the PRECAUTIONARY MESSAGE. Working capacity of the machine tool does not influence. |
| F08 | Shaft position sensor fault | Contact after-sales service office. |
| F12 | Error while gauge calibration | Repeat gauge calibration. If error repeats, contact after-sales service office |
| F13 | Error while imbalance sensors calibration | Report imbalance sensors calibration. If error repeats, contact after-sales service office. |
| F14 | Pressing the START key while cover is raised | Close the cover to start measurement |

ⓘ The error message in itself is not a guarantee case, and is only the tool for revealing of the reasons of the malfunctions leading to wrong functioning of the machine tool.

9.2 Other fault events and remedies

Table 9.2

| N | Fault description | Probable cause | Remedy |
|---|--|--|---|
| 1 | No indication upon switching on the machine | No power supply | Check the power wire and voltage |
| | | Fuse is blown | Replace the fuse |
| 2 | The results of several measurements differ for more than 10gr. (without the wheel remount) | Incorrect installation of the machine | Install the machine according to the requirements of section 2 |
| | | Wheel slip on the shaft | Clean and degrease installation surfaces of the shaft with the cup and wheel rim. Mount the wheel, set the aligning marks on the wheel and shaft, check the slip absence after measurement |
| | | Foreign objects in the shaft cup | Clean the shaft cup inner surface |
| | | Foreign objects, wastes, water under the tubeless tire cover | Detach the tire and clean it. |
| | | Impact of vibration and blows through the base | Eliminate the impact of vibration and blows during measurements |
| | | Insufficient shaft fastening | Remove the shaft and then mount it according to the requirements of section 2. |
| 3 | After the wheel is remounted, the results of measurements differ for more than 15gr. (for a wheel 13", width 5") | Dirty mounting surfaces of the rim and shaft | Clean mounting surfaces |
| | | Foreign objects, water in the tire | Detach the tire, withdraw the objects and dewater it. |
| | | Incorrect selection of the wheel fastening method or substandard wheel | Change the wheel fastening method or replace the wheel |
| | | Shaft calibration failure | Check shaft calibration. Bare shaft imbalance must not exceed 2 g. Calibrate the shaft again if needed (2.6.8). |
| 4 | After calibration the imbalance measurement accuracy doesn't conform to the requirements of this operations manual | Errors in operations during calibration, mechanical effects on the machine during calibration measurements | Repeat calibration |
| | | Reasons described in clauses 2, 3 of this table. | Eliminate in accordance with the given recommendations. |
| 5 | The machine is not switched on or switched off during operation, the signal sounds | The overvoltage protection device is activated. | Switch off the machine. Eliminate the reason of the overvoltage. Switch on the machine. |

If the appeared malfunction is not eliminated by the described method and if the malfunction event is not described in this section, so please consult the service department.

10 MAINTENANCE AND SAFETY REQUIREMENTS

10.1 Maintenance

10.1.1 The maintenance of the machine is the necessary condition for providing the correct operation of the machine; the maintenance shall be fulfilled by the operating staff in accordance with the present manual.

10.1.2 **IMPORTANT! DEENERGIZE THE MACHINE BEFORE PERFORMING THE MAINTENANCE.**

10.1.3 Keep the machine clean and free of dust and moisture. Do not flood or sprinkle the machine with water. Do not use acetone or other solvents for wiping the machine.

10.1.4 Check the spindle bolt tightening frequently.

10.1.5 Keep the thread segment of shaft clean and lubricated.

10.1.6 Eliminate the faults, indicated in the Table 9.2. Contact after-sales service office in the other cases.

10.1.7 It is not allowed to dismount the machine till the end of the warranty period.

10.1.8 If during operation standard wheel balancing with clip-on weights is fulfilled for more than one cycle, the machine should be checked, and the calibration of the machine should be performed, if necessary.

10.1.9 Monthly check shaft imbalance and make shaft calibration by necessity.

10.2 Safety requirements

10.2.1 The operating personnel shall read the present Manual and be aware of the machine operation features. The operating staff shall be also given the safety guidance instructions.

10.2.2 The machine should be grounded in accordance with electrical equipment operation rules. The grounding of the machine is effected automatically upon plugging in. When installing the machine, make sure that the plug grounding is in good condition.

10.2.3 The machine shall be operated in accordance with the Safety Rules related to operation of electrical equipment.

10.2.4 **IMPORTANT! THE VOLTAGE INSIDE THE MACHINE CAN BE UNSAFE. MAKE SURE THAT THE UPPER COVER OF THE MACHINE IS CLOSED DURING THE OPERATION.**

10.2.5 De-energize the machine before starting the maintenance works.

10.2.6 **IMPORTANT! IT IS NOT ALLOWED TO STAND IN THE AREA OF ROTATING PARTS DURING THE OPERATION.** During the wheel setting on the machine it's necessary to check the security of wheel attachment in order to avoid skipping of the wheel.

It is not allowed to brake the wheel with the hand.

10.2.7 **WARNING!** It's not allowed to operate the machine if the value of the «Safe start-up» is «no». Set the value «no» of the «Safe start-up» only for the duration of maintenance, observing all necessary safety rules!

10.3 Instructions for emergency cases

10.3.1 If an emergency situation in tire fitting area occurs, immediately de-energize the machine.

10.3.2 Conduct further actions in accordance with the safety instructions established on the Customer's plant.

11 STORAGE AND TRANSPORTATION

11.1 Storage

Whenever the machine is to be stored temporarily and during periods in which it is not in use, remove the electrical plug from the socket.

If the storage period does not exceed 1 month, the machine shall be stored in the enclosed space under the ambient temperature $+10^{\circ}$ - $+35^{\circ}\text{C}$, and relative air humidity not more than 80% (under the temperature $+25^{\circ}\text{C}$). The air shall be free from impurities, which can cause corrosion.

In case of impossibility of providing the abovementioned conditions, the machine shall be stored in the manufacturer's packing or in the package similar to the manufacturer's.

To prepare the machine to the long-term storage, clean and degrease the shaft extension with gasoline or white spirit. After the complete dryout of the solvent, coat the shaft with a flash of grease and wrap it in water-proof packing paper. Cover the machine with polyethylene film.

If the storage period exceeds 1 month, the machine shall be stored in the enclosed space with natural ventilation under the ambient temperature from -50° to $+50^{\circ}\text{C}$ and the relative air humidity not more than 90% (under the temperature $+20^{\circ}\text{C}$) with no moisture condensation.

11.2 Transportation

11.2.1 The packed machine can be conveyed in covered transport (railway cars, containers, covered motors) under the temperature -50° to $+50^{\circ}\text{C}$.

11.2.2 If conveyed by water transport, the packed machine shall be transported in waterproof cover.

11.2.3 Effect the transportation, loading and discharge carefully; do not turn the container over; do not put the container on its edge; avoid blows. If the machine is unpacked, avoid applying force to the spindle.

11.3 Information on recycling

The wheel balancer is categorized as special refuse and it should therefore be divided into homogenous parts and disposed of according to the laws in force.

APPENDIX A

(for reference)

Table A.1 Flange holes parameters

| Diameter of bolts arrangement, mm | Number of bolts, pieces |
|-----------------------------------|-------------------------|
| 139.7 | 5 |
| 115 | 5 |
| 170 | 3 |
| 108 | 5 |

Table A2 Information on wheel mounting holes of some car models.

| |
|---|
| 5 holes on rim of diameter 108 mm |
| GAZ: Volga 3110 |
| ALFA ROMEO: 166 |
| CITROEN XM, XM-XM BREAK |
| JAGUAR: X-TYPE |
| FERRARI: 324, 512TR-MONDIAL-348-TESTAROSSA |
| FORD: MONDEO-TRANSIT Connect, TRANSIT Connect Tourneo |
| LANCIA Gamma, Kappa |
| PEUGEOT: 605('89-) |
| RENAULT: R21/R25/Safrane/Espace/Laguna |
| ROMEO MONTREAL |
| VOLVO: 200,700,900 |
| VOLVO: C70-S60-S70-S80-S90-V70-V70-XC 740-760-940-960, 850-V90 |
| 6 holes on rim 170 mm in diameter |
| GAZ: Gazel |
| MITSUBISHI: CANTER T35 |
| OPEL: Bedford CF350 |
| 5 holes on rim 139,7 mm in diameter |
| GAZ: Volga |
| VAZ: Niva |
| UAZ |
| DAIHATSU: Wildcat/Rocky/Feroza |
| FORD: Bronco |
| KIA: ROCSTA-SORENTO, RETONA-SPORTAGE |
| ROLLS ROYCE: Silver Cloud/Phantom |
| SUZUKI: LJ80/SJ410/Vitara/SJSamurai/X90 |
| 5 holes on rim 115 mm in diameter |
| Moskvich 2140, 412 |
| GENERAL MOTORS CHEVROLET: PONTIAC TRANS-SPORT-CHEVROLET AURORA-CADILLAC CTS (02-04) |
| OPEL: SINTRA |

APPENDIX B



(informational)



Table B.1 - List of Programs

| | | |
|------------|-------------|--|
| P01 | drt | Wheel Parameters Measurement Mode Settings |
| P02 | Thr | Zeroing threshold |
| P03 | CPS | Adapter Imbalance Compensation |
| P04 | CA.G | Gauge Arms Calibration |
| P05 | CA.0 | Shaft Calibration |
| P06 | CA.S | Imbalance Sensors Calibration |
| P07 | SFt | Start-up blocking with the cover raised |
| P08 | Cnt | Wheel Counter |
| P09 | Uer | Software Version |
| P10 | PAr | Manual Input of Wheel Parameters |
| P11 | Aut | Autotransition into "New Wheel" |
| P12 | Er.L | To view a list of messages about errors |
| SEr | SEr | To enter the Service Menu |

Table B.2 - List of Programs in Service Menu

| Number | Mark | Name | Parameters |
|------------|-------------|--|---|
| S01 | AnG | Shaft Position Sensor Diagnostics | *- <index><F2><F1> - angle position of the shaft |
| S02 | re.L | Gauge Arm Sensor of distance (potentiometer) Diagnostics | *- value in ADC unit if point is at the end (<999.>) - value in mm |
| S03 | re.d | Diameter Sensor(resistor) Diagnostics | *- value in ADC unit if point is at the end (<999.>) - value in mm (<999>) - value in mm (<99.9>) |
| S04 | PiE | Imbalance Sensors Diagnostics (piezo sensors) | **value in ADC unit Ch0 – vertical sensor Ch1 – horizontal sensor |
| S05 | Cou | Cover Sensor Diagnostics | Sensor value |
| S06 | StA | Statistical Measurements | *** |
| S07 | Fct | To view calibration factors | *** |
| S08 | SiG | To view the last measurement signals | *** |
| S09 | diS | To view the last measurement imbalance | *** |
| S10 | Cor | To view the correction planes parameters | *** |

*press  ,  to change parameter;

** press  ,  to change parameter. After 1st pressing the mark of the current program is displayed temporary. After 2nd pressing parameter as changed.

*** for manufacturing purposes only

**THE CARTEK GROUP
6950 EAST N AVENUE
KALAMAZOO, MI 49048
PH: 866-550-1134**

WWW.BEAR-CARTEK.COM